

CoroCAM[®] Product Catalog

We manufacture and supply UV emission visualization cameras that offers a full range of combined Ultra Violet, Infrared and Visible inspection systems in handheld and aerial applications to the world's Power Industry. The CoroCAM[®] cameras gives power utilities the ability to determine where preventative maintenance should be performed to avoid outages and equipment failure.

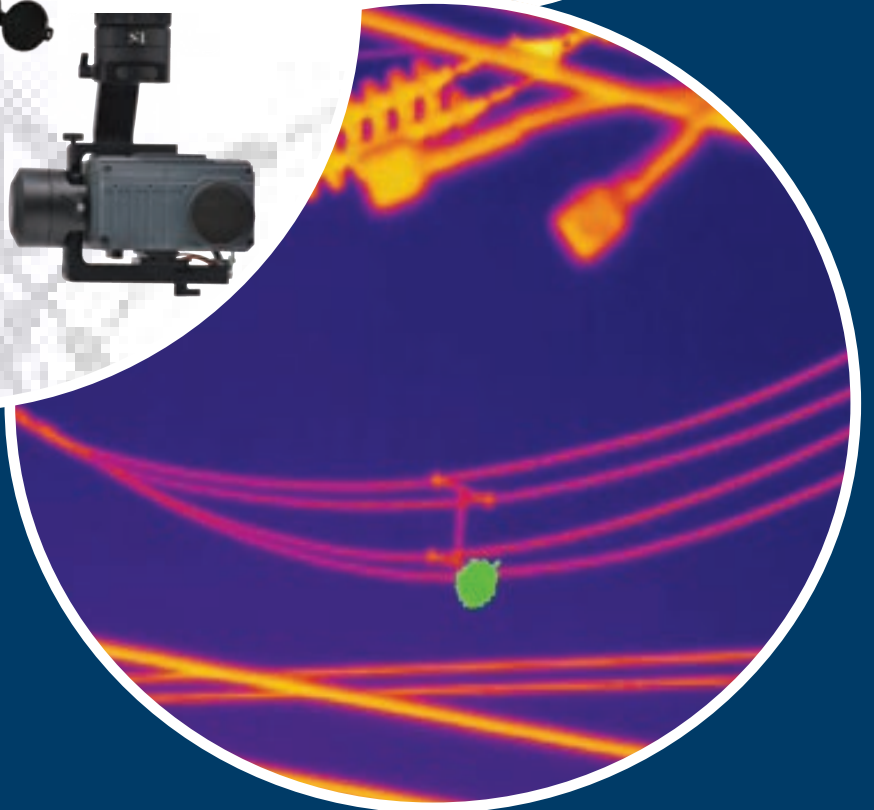

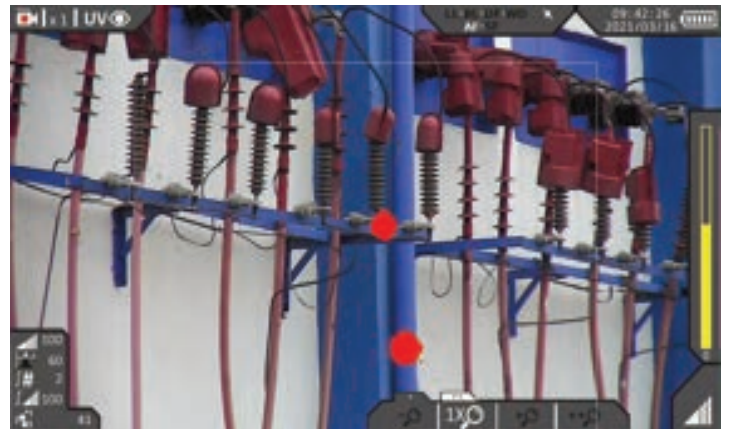

CoroCAM[®] 6HD

High Performance Daylight Corona Imaging Camera

The CoroCAM 6HD is an easy to operate, robust system which delivers high sensitivity and resolution in a lightweight package. Ergonomic design, a large LCD display and the use of commercially available batteries and a neckstrap allows the camera operator to work all day under all applicable conditions.

NOTABLE FEATURES:



NOTABLE FEATURES:

- A high sensitivity detector, which can detect UVc emissions down to $2.05 \times 10^{-18} \text{ W/cm}^2$, this allows for the detection of the smallest corona discharges.
- UV Gain, threshold or integration can be set to optimize the resulting image.
- Factory fitted standard Motorized Solar Blind (SB) filter position module can remove the solar blind filter from the light path to enhance sensitivity - Non Solar Blind (NSB) Module. Corona signals above the threshold level are displayed in real time.
- The UV count is adjusted to compensate for camera settings.
- High sensitivity color video camera with a resolution of 1920 x 1080 pixels which can operate at light levels down to 0.03 Lux @ F1.6 at Full Frame rate; rendering it capable for conducting inspections at night.
- Synchronized UV & Visible Zoom from 1x (defined as $8^\circ \times 6^\circ / 10^\circ$ Diagonal) up to 2x system zoom (optical/ digital for the Visible Channel and digital for the UV channel). A maximum of 12x digital zoom is available for the visible channel.
- Automatic or Manual visible camera focus control from $<0.7\text{m}$ to infinity. UV camera focus can be set manually or slaved to the visible camera focus position.
- The visible image can be enhanced for back-light compensation to set to low light mode.
- UV is overlaid onto the visible in one of the 4 preset or 100 user selected colors.
- The UV overlay translucency can be adjusted to show the discharge source.
- On-board still image and video recording in high quality formats (720p for video).
- Fast set up & boot up avoids the need for power saving modes.
- 18 Month warranty, extendable to 36 months.



The CoroCAM 6HD (installed in a suitable gimbal) can be lofted by a number of enterprise grade UAV's. The mini-HDMI or composite video output can be down-linked to a base station display, while the RS232 port can accept remote control signals from a base station via a RS23 transmitter.

Recordings can be made on the camera while being remote controlled. This makes the CoroCAM 6HD ideal for inspectors who want to transition into the use of UAV's.

CoroCAM 6HD lofted by Aerialtronics Altura Zenith ATX8

COROCAM 6HD PHOTOS:

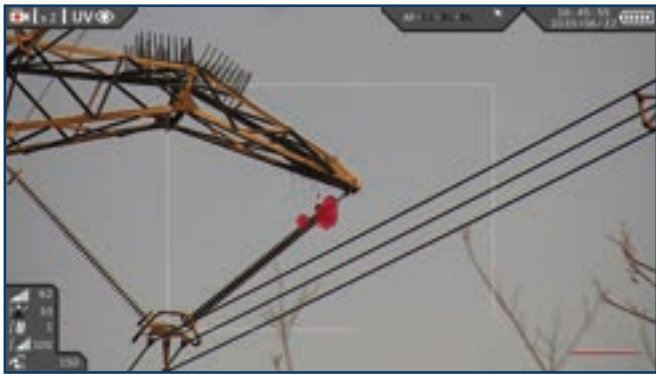
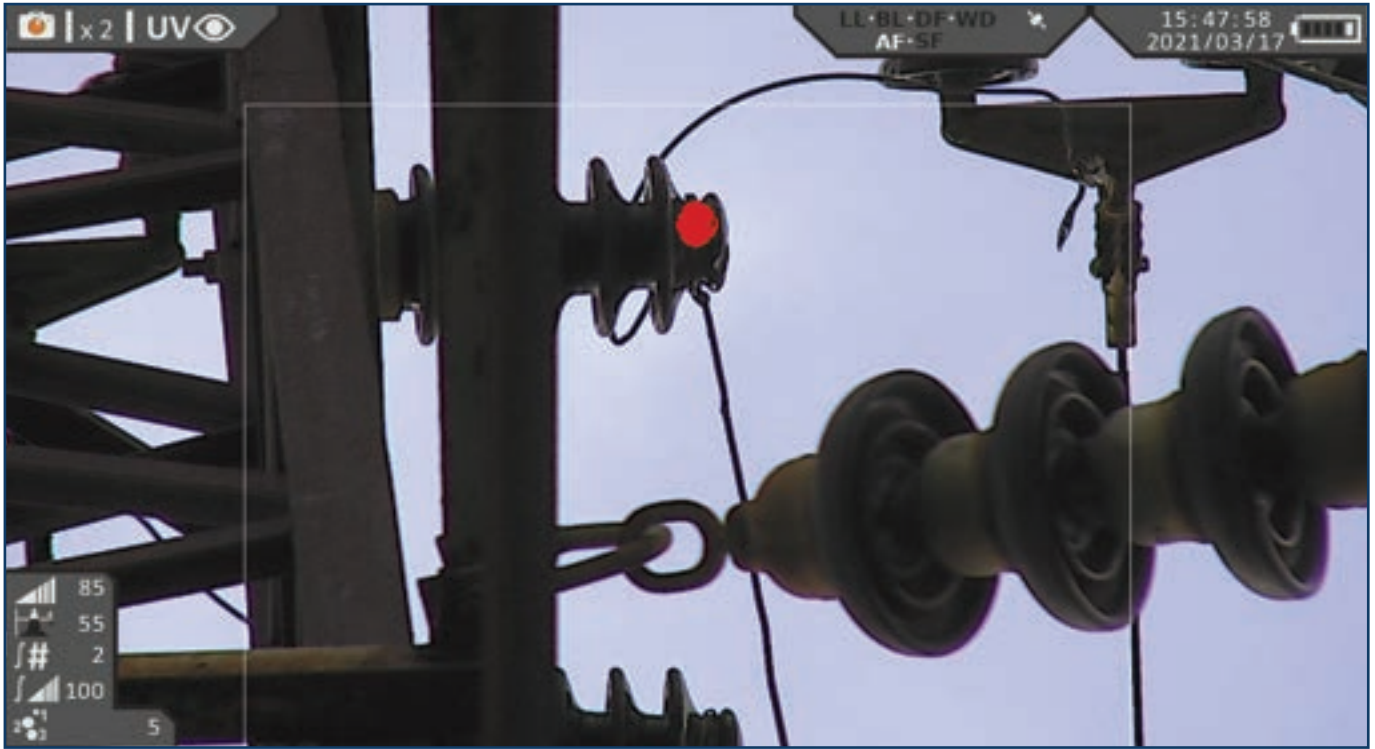

Typical view

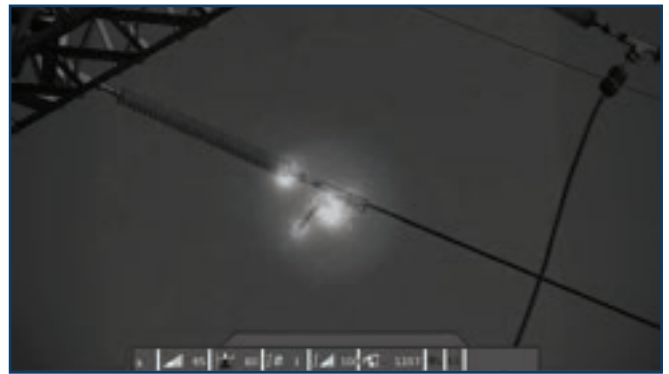

Background Priority View

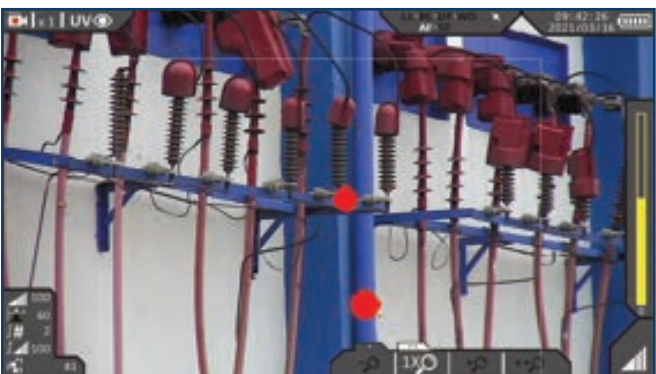

SYSTEM SPECIFICATIONS:

CoroCAM 6HD Brochure Version: 2023/1
Specifications subject to change without notice

ULTRAVIOLET CHANNEL

Typical Sensitivity:	SB (240 - 280 nm) 2.05×10^{-18} Watt/cm ² , 3pC @ 20m (Korea Electrotechnology Research Institute IEC 60270:2000) 13.16dB μ V(RIV) @ 1MHZ @ 10m (Korea Electrotechnology Research Institute – NEMA107-1987) ; Optional NSB (240-300 nm) $\sim 1 \times 10^{-18}$ Watt/cm ² , 0.8pC @ 15 m Tested & certified by Innogy SE-Eurotest Germany: IEC 60270:2000
Field of view:	8° Horizontal x 6° Vertical \sim 10° Diagonal Zoom Range (optical): 1x Zoom Range (digital): 8° to 4°, in 1 step
Focus type:	Linked to Visible with manual override
Focus Range:	<0.7m to Infinity
Detector Life Span:	No degradation
Corona Measure Method:	Intensity based count, Calibrated for irradiance value of selected area
Threshold Mask:	Useful range 20-100%
UV Transparency:	0-100%
UV False Color Selection:	4 presets with 100 user selectable hues
UV Integration:	Adjustable period, Summation or Noise Reduction

VISIBLE CHANNEL

Resolution:	1920 x 1080 pixels
Sensitivity Day Mode:	0.05 Lux F1.6
Sensitivity Night Mode:	0.03 Lux F1.6
Exposure / Image Enhancements:	Auto or Manual
Focus Type:	Automatic with manual override
Focus Range:	<0.7m to Infinity
Useful Zoom Range (optical):	16° (0.5x) to 4° (2x)
Camera Module Zoom Range:	10x Optical zoom, 53° to 4.9°
Zoom type:	Stepped
Zoom Range (digital):	4x, 6x, 8x, 12x
Maximum IFOV:	0.0445 mRAD

IO & OS

OS Features:	Icon based menu system, 10x User Profile. Boot to inspection capable in 6s, to record capable in 60s. Image Sort Numbering. Video list and playback.
Input:	Keypad (right hand)
Output:	HDMI & Composite Video
Bi-Directional:	Mini USB, RS-232
Firmware:	Internal GPS, with external hotplug booster antenna
Software Update:	Via files downloaded from website to Mirco SD card

SYSTEM SPECIFICATIONS:

CoroCAM 6HD Brochure Version: 2023/1
Specifications subject to change without notice

DISPLAY

Type:	5.7" LCD, 640 x 480 pixels, color, manual or auto brightness up to 450cd/m ² , variable angle
Display Modes:	UV+Vis, VIS only, UV only, UV Priority
UV Overlay Accuracy:	<1 milirad deviation
On Screen Display:	Gain, zoom, count, active functions

POWER

Battery:	Sony Li-ion, Type L compatible
Battery Location:	Internal, quickly replaceable
Power Consumption:	9 Watt
Operating Time:	>3hrs maximum, 2.5hrs typical
Continuous Operation:	No overheating
Charging:	In camera or in external charger
External Power Supply:	9-16V 12VA - Car or mains adapter Mains Adaptor: 110-240 V ac 50 - 60 Hz / 12 V dc 3A Protection: Reverse polarity, over current, under voltage

PHYSICAL SPECIFICATION

Weight:	1.9 kg including battery
Dimensions:	220 mm L x 160 mm W x 80 mm H
Window aperture:	Ø = 62 mm
Operating & Storage Temp:	-20 °C to 55 °C
Humidity:	Up to 90 %, non condensating
Mounting Point	Standard 1/4" X20 thread tripod mount

PROTECTION

Storage / Transport Case:	Pelican style plastic hard case
Environmental Protection:	IP54 / MIL-STD 810F (Vibration, shock, temperature, humidity)
Safety Standard:	CE, IEC61010-1
Warranty:	18 months

ACCESSORIES

Reporting Software:	CoroBASE
Carrying:	Neckstrap
	Camera Harness



Website: www.uvirco.com
Address: UVIRCO Technologies (Pty) Ltd,
33 De Havilland Crescent, Perseus Technopark, Pretoria 0020, South Africa
Tel: +27 (0)12 349 3760 | Fax: +27 86 435 5204 | Email: info@uvirco.com



CoroCAM[®] 7HD

Professional Solar Blind Corona Camera

The CoroCAM 7HD makes location of corona discharges fast and effective. Highly zoomed HD imagery allows for the visualisation of the finest details. Easy to use features brings powerful performance. Optimise the camera sensitivity using the adjustable Long Integration, Noise Reduction, UV Threshold Level and Non-Solar Blind Mode (when applicable). Optimise the UV blob display using the UV Blob False Color, Blob Transparency and the adjustable Background Priority. The adjustable viewfinder, LCD display and rotatable grip makes for optimal ergonomics and allows the operator to use the camera in all light conditions from multiple stances, minimising muscle fatigue.

A built-in flashlight and Motorised Non-Solar Blind module makes this the perfect choice for indoor inspections.

NOTABLE FEATURES:

Adjustable and focusable viewfinder

One handed operation

Onboard microphone and speaker

Rotating LCD Display

Instruction sticker



GPS booster antenna port

Laserpointer

Integrated high power flashlight with adjustable brightness levels



Ventilated viewfinder

Easily replaceable Li-ion batteries

I/O connectors
Ethernet, USB, HDMI,
Micro SD Card

RS232/485



NOTABLE FEATURES:

- High sensitivity detector, which can detect UVC emissions down to $2.05 \times 10^{-18} \text{ W/cm}^2$, this allows for the detection of the smallest corona discharges.
- Motorized Solar Blind (SB) filter removal in Non-Solar Blind (NSB) mode to increase sensitivity for use at night or indoors. Users can select optimised presets for detection or location of discharges.
- Corona signals above the threshold level are displayed in real time.
- High zoom visible camera with a resolution of 1920 x 1080 pixels, recorded at 720p.
- Image Enhancements - Wide Dynamic Range and De-fog
- improves visible image quality in challenging conditions.
- Synchronized UV & Visible Zoom from 1x (defined as 8° x 6° / 10° Diagonal) up to 4x system zoom (optical for the Visible Channel and digital for the UV channel).
- Onboard still image and video recording in JPG and AVI formats.
- UCF metadata file containing uncompressed displayed image and raw UV image, camera settings and preset values.
- Fast boot up avoids the need for power saving modes.
- User profile setup, save and restore.
- Camera software update via download to Micro SD card.
- 18 Month warranty, extendable to 36 months.

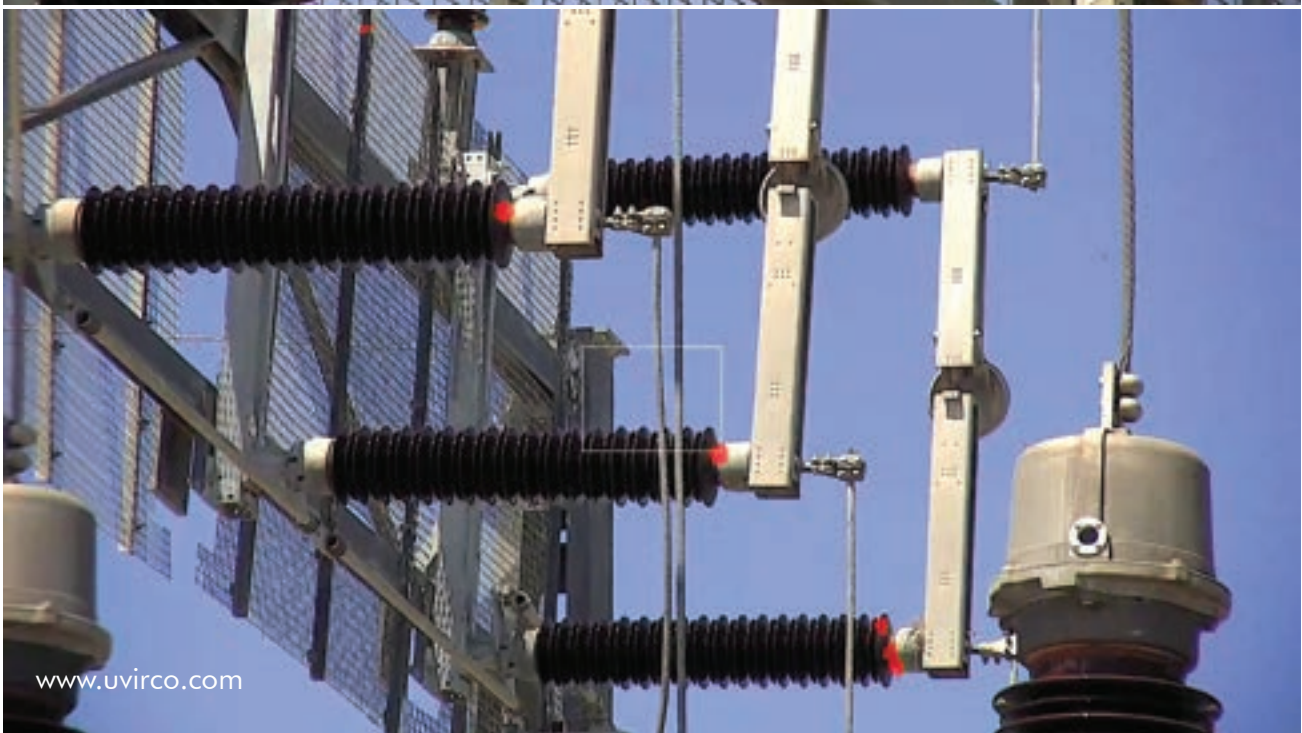

SYSTEM SPECIFICATIONS:

CoroCAM 7HD 2023 Brochure
Specifications subject to change without notice

ULTRAVIOLET CHANNEL	
Typical Sensitivity:	SB (240 - 280 nm) 2.05×10^{-18} Watt/cm ² , IEC 60270:2000: 3pC @ 20m (Korea Electrotechnology Research Institute) & 1.8pC @ 10m (Innogy) NEMA107-1987: 13.16dB μ V(RIV) @ 1MHZ @ 10m (Korea Electrotechnology Research Institute)
	NSB (240-300 nm) $\sim 1 \times 10^{-18}$ Watt/cm ² , 0.8pC @ 10 m Tested & certified by Innogy SE-Eurotest Germany: IEC 60270:2000
Field of view:	8° Horizontal x 6° Vertical $\sim 10^\circ$ Diagonal Zoom Range (optical): 1x Zoom Range (digital): 16° to 2°, in 4 steps
Focus type:	Linked to Visible with manual override
Focus Range:	<0.7m to Infinity
Detector Life Span:	No degradation
Corona Measure Method:	Intensity based count, Calibrated for irradiance value of selected area
Threshold Mask:	Useful range 20-100%
UV Transparency:	0-100%
UV False Color Selection:	6 pre-set colors, 100 user selectable hues
UV Integration:	Adjustable period, Summation or Noise Reduction

VISIBLE CHANNEL	
Resolution:	1920 x 1080 pixels
Sensitivity Day Mode:	0.1 Lux F1.6
Sensitivity Night Mode:	0.05 Lux F1.6
Exposure / Image Enhancements:	Auto or Manual
Focus Type:	Automatic with manual override
Focus Range:	<1.5m to Infinity
Useful Zoom Range (optical):	16° (0.5x) to 2° (2x)
Camera Module Zoom Range:	30x Optical zoom, 58.9° to 2,11°
Zoom type:	Stepped and Smooth
Zoom Range (digital):	4x, 6x, 8x, 12x
Maximum IFOV:	0,01917 mRAD / 52.1629

IO & OS	
OS Features:	Icon based menu system, 10x User Profile. Boot to inspection capable in 6s, to record capable in 60s. Image Sort Numbering. Video list and playback.
Input:	Keypad (right hand), Onboard & External Microphone
Output:	HDMI & Composite Video; Onboard speaker
Bi-Directional:	Mini USB, RS-232; Optional Wi-Fi
Firmware:	Internal GPS, with external hotplug booster antenna LED Flashlight (Adjustable Brightness, 10-100% usable range)
Software Update:	Via files downloaded from website to Mirco SD card

MEDIA & DATA STORAGE	
Storage Medium:	Micro SD card (32 GB supplied with camera)
Storage Format Video:	AVI, 720p (H.264 compression)
Storage Format Still:	JPG, AVI, UCF
Media Download:	Via Card Reader or USB

SYSTEM SPECIFICATIONS:

CoroCAM 7HD 2023 Brochure
Specifications subject to change without notice

DISPLAY

Type:	5.7" LCD, 640 x 480 pixels, color, manual or auto brightness up to 450cd/m ² , variable angle. Viewfinder, 800x600, Focusable, Adjustable Angle, Ventilated rubber eye piece.
Display Modes:	UV+Vis, VIS only, UV only, UV Priority
UV Overlay Accuracy:	<1 milirad deviation
On Screen Display:	Gain, zoom, count, active functions

POWER

Battery:	Sony Li-ion, Type L compatible
Battery Location:	Internal, quickly replaceable
Operating Time:	>3hrs maximum, 2.5hrs typical
Continuous Operation:	No overheating
Charging:	In camera or in external charger
External Power Supply:	9-16V 12VA - Car or mains adapter Mains Adaptor: 110-240 V ac 50 - 60 Hz / 12 V dc 3A Protection: Reverse polarity, over current, under voltage

PHYSICAL SPECIFICATION

Ergonomics:	Rotatable grip w/ one handed keypad
Weight:	2.2 Kg including battery
Dimensions:	275 mm L x 135 mm W x 190 mm H
Window aperture:	Ø = 62 mm
Operating Temp:	-15 °C to 55 °C
Storage Temp:	-20 °C to 60 °C
Humidity:	Up to 90 %, non-condensing
Mounting Point	Standard 1/4" X20 thread tripod mount

PROTECTION

Storage / Transport Case:	Pelican style plastic hard case
Environmental Protection:	IP55
Safety Standard:	CE, IEC61010-1
Warranty:	18 months

ACCESSORIES

Reporting Software:	CoroBase
Carrying:	Neckstrap & Camera Harness



Website: www.uvirco.com
Address: UVIRCO Technologies (Pty) Ltd,
33 De Havilland Crescent, Perseus Technopark, Pretoria 0020, South Africa
Tel: +27 (0)12 349 3760 | Fax: +27 86 435 5204 | Email: info@uvirco.com



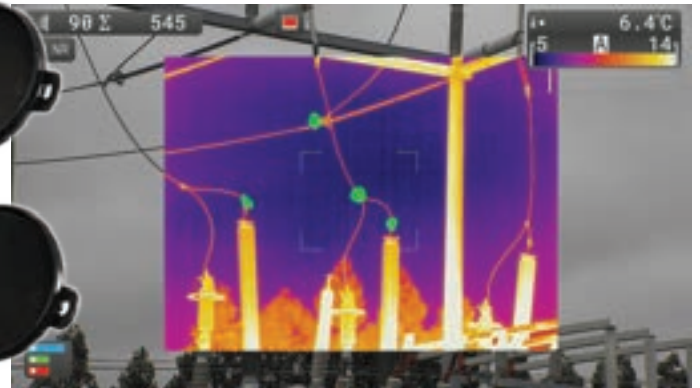

CoroCAM[®] 8HD

Combined LWIR and Corona Camera

The CoroCAM 8HD combines a FLIR radiometric thermal camera with the CoroCAM Solar Blind UV camera system, allowing simultaneous detection and location of corona discharges and hot spots, saving time and effort. Co-location of electrical discharges and hot spots give the inspector more insight into the cause of fault conditions.

Advanced UVc image enhancement features are available to increase sensitivity (adjustable Long Integration & Non-Solar Blind Mode), reduce false signals (adjustable Noise Reduction & Threshold Level) and improve the visibility of the discharge indicating blob (adjustable Background Priority, Blob Transparency and Blob False Colour). The rotating ergonomic grip, viewfinder and LCD display allows the operator to use the camera in all light conditions from multiple stances, minimising muscle fatigue.

FEATURES & PERFORMANCE:

Flip up LCD Display
5.7" with 640 x 480
pixels resolution

Quick guide

Short cut keys on the
left

Viewfinder

Easily replaceable
Li-ion batteries

Mini HDMI Output

I/O connectors
(Ethernet, USB,
RS232/485, Micro-SD
card)



Onboard microphone
& speaker and power
key

Simple powerful user
interface

Ventilated Viewfinder

One handed operation



- High sensitivity solar blind UV detector.
- 9Hz (optional 25 Hz) FLIR Radiometric LWIR camera module.
- Synchronized Smooth or Stepped Zoom of all 3 camera channels.
- IR & UV channels are zoomed digitally, visible is zoomed optically to minimum FOV, then digitally enlarged.
- Manual or Auto focus for Visible channel, UV & LWIR channel has manual focus or can be synchronized with the Visible.
- Onboard still image, video and radiometric data recording.
- Meta data recording of camera settings and measurement plus environmental variables manually entered - distance, air temperature, air pressure, ambient humidity and wind speed.
- Fast set up & boot up avoids the need for power saving modes.
- Manual or Auto Exposure of Visible and LWIR (Level) cameras, UV (Gain) is manually set.

- Easy & comfortable operation of the camera via the Rotational handle (right hand only) with primary multi-function interface keys.
- Control over UV overlay colors (6 pre-sets & 100 user selectable hue levels), UV overlay translucency, UV threshold, Integration & Noise Reduction control.
- 14 IR color palettes with contrasting Isotherms.
- Auto or Manual IR Span.
- GPS booster antenna port.
- Integrated high power LED flashlight with adjustable brightness levels & laser pointer.
- Camera software update via download to Micro-SD card.
- 12 month warranty.



SYSTEM SPECIFICATIONS:

CoroCAM 8HD Brochure Version: 2023/1
Specifications subject to change without notice

ULTRAVIOLET CHANNEL

Typical Sensitivity:	SB (240 - 280 nm) 2.05×10^{-18} Watt/cm ² ; IEC 60270:2000: 3pC @ 20m (Korea Electrotechnology Research Institute) & 1.8pC @ 10m (Innogy) NEMA107-1987: 13.16dB μ V(RIV) @ 1MHZ @ 10m (Korea Electrotechnology Research Institute)
	NSB (240-300 nm) $\sim 1 \times 10^{-18}$ Watt/cm ² , 0.8pc @ 15m Tested & certified by Innogy SE-Eurotest Germany: IEC 60270:2000
Field of view:	8° Horizontal x 6° Vertical $\sim 10^\circ$ Diagonal Zoom Range (optical): 1x Zoom Range (digital): 8° to 2°, in 3 steps
Focus type:	Linked to Visible with manual override
Focus Range:	<0.7m to Infinity
Detector Life Span:	No degradation
Corona Measure Method:	Intensity based count, Calibrated for irradiance value of selected area
Threshold Mask:	Useful range 20-100%
UV Transparency:	0-100%
UV False Color Selection:	6 pre-set colors, 100 user selectable hues
UV Integration:	Adjustable period, Summation or Noise Reduction

THERMAL

Detector Type:	VOx Microbolometer
Spectral Band:	7.5 - 13.5 μ m
Temperature Range:	-40°C to 160°C
Sensitivity:	Infrared (NE Δ T): <62.5mK @ f1.25
Focus Range:	2.3m to Infinity
Resolution:	640 x 512
Field of View:	10.4° x 8.3°
Zoom:	8x digital
IFOV:	0.283 mRAD
Readout:	<9 or 25Hz
IR Palettes	15x palettes / Isotherms
Level & Span	Auto or Manual

VISIBLE CHANNEL

Resolution:	1920 x 1080 pixels
Sensitivity Day Mode:	0.1 Lux F1.6
Sensitivity Night Mode:	0.05 Lux F1.6
Exposure / Image Enhancements:	Auto or Manual
Focus Type:	Automatic with manual override
Focus Range:	<1.5m to Infinity
Useful Zoom Range (optical):	16° (0.5x) to 2° (2x)
Camera Module Zoom Range:	30x Optical zoom, 58.9° to 2,11°
Zoom type:	Stepped and Smooth
Zoom Range (digital):	4x, 6x, 8x, 12x
Maximum IFOV / Δ K:	0.01917 mRAD / 52.1629

DISPLAY

Type:	5.7" LCD, 640 x 480 pixels, color, manual or auto brightness up to 450cd/m ² , variable angle
	Viewfinder, 800x600, Focusable, Ventilated rubber eye piece
Display Modes:	UV+Visible, UV+LWIR, Visible only, LWIR only, UV only, UV Priority
UV Overlay Accuracy:	<1 milirad deviation
On Screen Display:	Gain, zoom, count, active functions

SYSTEM SPECIFICATIONS:

CoroCAM 8HD Brochure Version: 2023/1
Specifications subject to change without notice

IO & OS	
OS Features:	Icon based menu system 10x User Profiles Boot to inspection capable in 6s, to record capable in 60s. Image Sort Numbering Video list and playback
Input:	Keypad (right hand), Onboard & External Microphone
Output:	Composite Video Onboard speaker
Bi-Directional:	Micro USB, RS-232
Firmware:	Internal GPS, with external hotplug booster antenna LED Flashlight (Adjustable brightness , 10- 100% usable range)
Software Update:	Via files downloaded from website to Mirco SD card

MEDIA & DATA STORAGE	
Storage Medium:	Micro SD card (>= 64 GB supplied with camera)
Storage Capacity:	1000+ images or >1 hr video/GB
Storage Format Video:	AVI, 720p (H.264 compression)
Storage Format Still:	JPG
Storage Format Radiometric Still:	UCF
Media Download:	Via Card Reader or USB

POWER	
Battery:	Sony Li-ion, Type L compatible
Battery Location:	Internal, quickly replaceable
Operating Time:	3hrs maximum
Continuous Operation:	No overheating
Charging:	In camera or in external charger
External Power Supply:	9-16V 12VA - Car or mains adapter Mains Adaptor: 110-240 V ac 50 - 60 Hz / 12 V dc 3A Protection: Reverse polarity, over current, under voltage

PROTECTION	
Storage / Transport Case:	Pelican style plastic hard case
Environmental Protection:	IP43
Safety Standard:	CE, IEC61010 - 1
Warranty:	12 months

PHYSICAL SPECIFICATION	
Ergonomics:	Rotatable grip w/ one handed keypad
Weight:	2.5 Kg including battery
Dimensions:	215 mm L x 200 mm W x 155 mm H
Window aperture:	Ø = 62 mm
Operating Temp:	-15 °C to 55 °C
Storage Temp:	-20 °C to 60 °C
Humidity:	Up to 90 %, non condensating
Mounting Point	Standard 1/4" X20 thread tripod mount

ACCESSORIES	
Reporting Software:	CoroBASE
Carrying:	Neckstrap & Camera Harness



Website: www.uvirco.com
Address: UVIRCO Technologies (Pty) Ltd,
33 De Havilland Crescent, Perseus Technopark, Pretoria 0020, South Africa
Tel: +27 (0)12 349 3760 | Fax: +27 (0)86 435 5204 | Email: info@uvirco.com



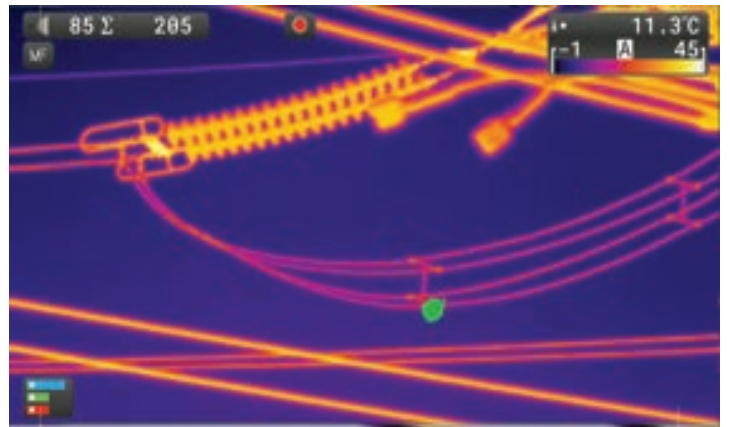

CoroCAM[®] 8HD UAV

Combined LWIR, Solar Blind UV Corona and HD Visible Camera for UV Applications

The CoroCAM 8HD UAV combines a FLIR LWIR, Solar Blind corona and HD video camera into one system, sized and balanced to fit into a standard commercial UAV gimbal for mounting onto UAV's. The false coloured UV blobs fused onto the HD visible or radiometric LWIR image indicate the presence of corona discharges. The HD visible cameras high optical zoom and the safe close approach of the UAV to the hardware under inspection, allows the system to capture more detailed images of the physical condition of the hardware from all angles, allowing inspectors to better assign a maintenance priority. The camera can also be dismantled for man-portable inspections.

FEATURES & PERFORMANCE:

LED Flashlight & Laser pointer

Remote Control receiver port

Tripod mount



HDMI, USB, Composite Video Output

RS232 & SD Card Slot

Ethernet port & Power Input

Mounting bracket for external screen

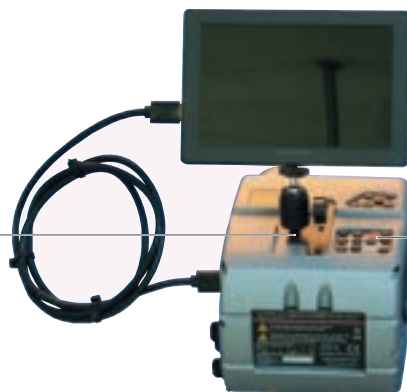

Easy operation via a multi - function keypad when used from tripod or hand carried



FEATURES & PERFORMANCE:

- High sensitivity UV detector, which can detect UVc light at 2.05×10^{-18} Watt/cm², this allows for the detection of the smallest corona discharges.
- 9Hz (or optional 25Hz) Radiometric IR camera module.
- Synchronized Smooth or Stepped Zoom of all 3 camera channels.
- IR & UV channels are zoomed digitally, visible is zoomed optically to minimum FOV, then digitally enlarged.
- Manual or Autofocus for the Visible channel, UV and IR channels has manual focus or can be synchronized with the Visible channel.
- Onboard still images, video and radiometric data recording in high-quality formats.
- Metadata recording of camera settings and measurements plus environmental variables manually entered - distance, air, temperature, air pressure, ambient humidity, and wind speed.
- The On Screen Display (OSD) shows all the relevant information.
- Manual or Auto Exposure of Visible and IR (Level) cameras, UV (Gain) is manually set.
- Integrated GPS with internal and complementary external booster antenna.
- UV overlay colors have 6 pre-sets or 255 selectable hue levels.
- UV overlay translucency control.
- UV threshold, Integration & Noise Reduction control.
- 14 IR color palettes with contrasting Isotherms.
- Auto or Manual IR Span.
- Camera software update via download to SD card.
- Internal or External power supply.
- 12 Month warranty.

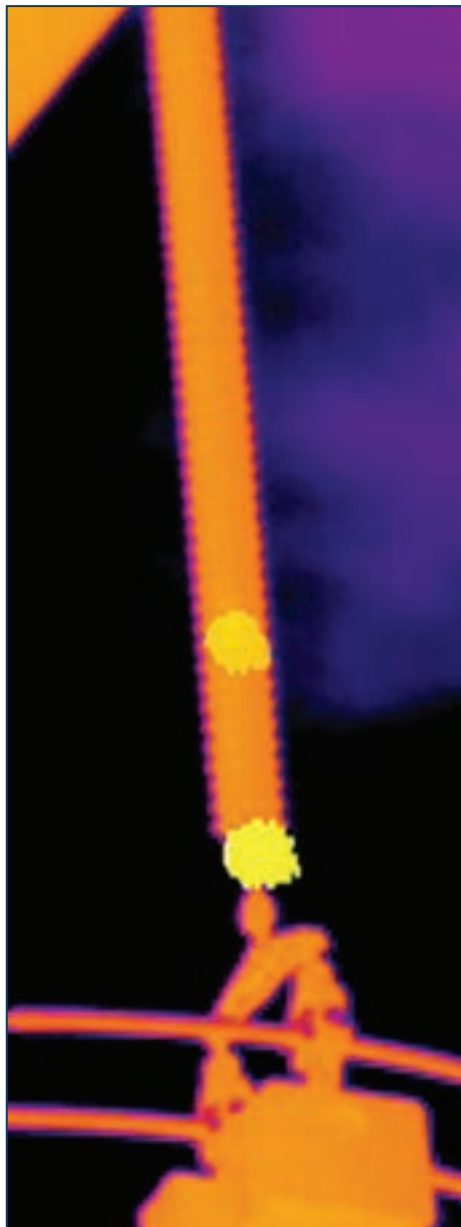
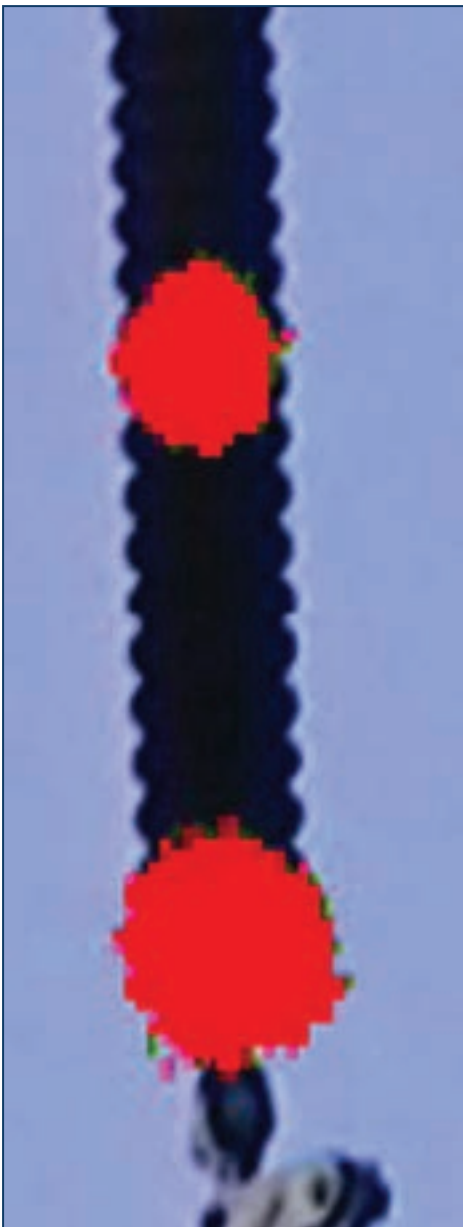

DIMENSIONS:

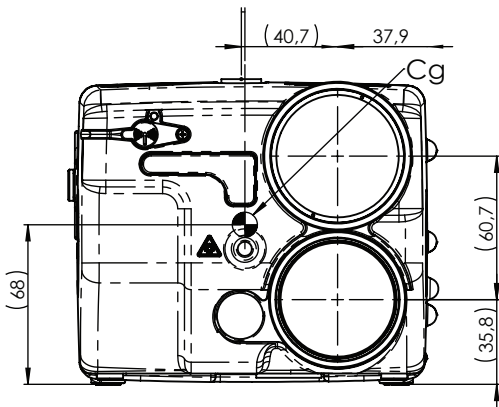

Front view

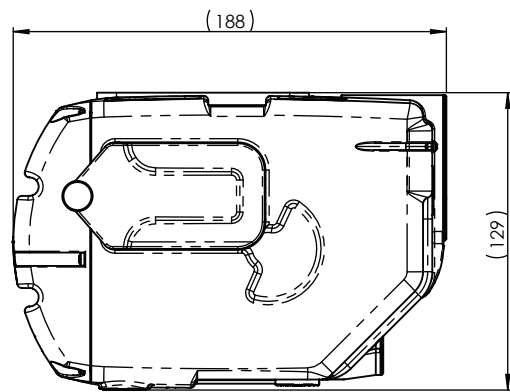

Side view

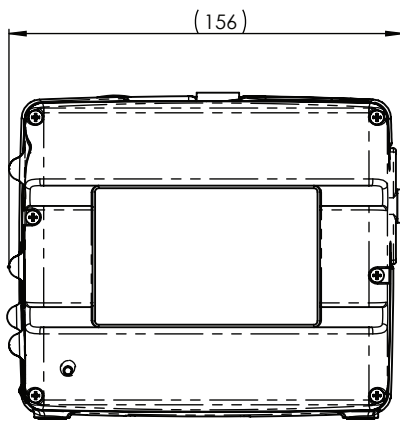

Back view

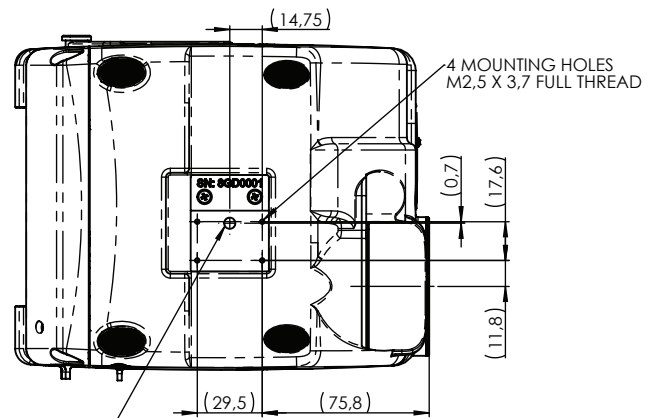

Bottom view

MOUNTING HOLE
1/4"-20 UNC X 3,7 FULL THREAD

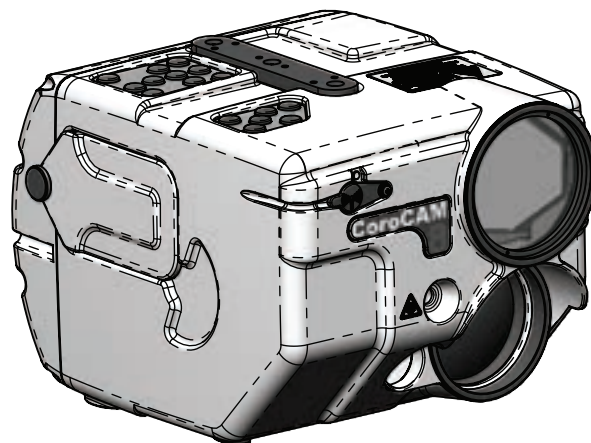

ALL DIMENSIONS IN mm Tol +0.1 -0.1mm

SYSTEM SPECIFICATIONS:

CoroCAM 8HD UAV Brochure Version: 2023/1
Specifications subject to change without notice

ULTRAVIOLET CHANNEL	
Typical Sensitivity:	SB (240 - 280 nm) 2.05x10 ⁻¹⁸ Watt/cm ² ; IEC 60270:2000: 3pC @ 20m (Korea Electrotechnology Research Institute) & 1.8pC @ 10m (Innogy) NEMA107-1987: 13.16dBµV(RIV) @ 1MHZ @ 10m (Korea Electrotechnology Research Institute)
	NSB (240-300 nm) ~ 1 x 10 ⁻¹⁸ Watt/cm ² , 0.8pC @ 15 m Tested & certified by Innogy SE-Eurotest Germany: IEC 60270:2000
Field of view:	8° Horizontal x 6° Vertical ~ 10° Diagonal Zoom Range (optical): 1x Zoom Range (digital): 8° to 2°, in 3 steps
Focus type:	Linked to Visible with manual override
Focus Range:	<0.7m to Infinity
Detector Life Span:	No degradation
Corona Measure Method:	Intensity based count, Calibrated for irradiance value of selected area
Threshold Mask:	Useful range 20-100%
UV Transparency:	0-100%
UV False Color Selection:	6 pre-set colors, 100 user selectable hues
UV Integration:	Adjustable period, Summation or Noise Reduction

THERMAL	
Detector Type:	VOx Microbolometer
Spectral Band:	7.5 - 13.5 µm
Temperature Range:	-40°C to 160°C
Sensitivity:	Infrared (NEdT): <62.5mK @ f1.25
Focus Range:	2.3m to Infinity
Resolution:	640 x 512
Field of View:	10.4° x 8.3°
Zoom:	8x digital
IFOV:	0.283 mRAD
Readout:	<9 0r 25Hz
IR Palettes	15x palettes / Isotherms
Level & Span	Auto or Manual

VISIBLE CHANNEL	
Resolution:	1920 x 1080 pixels
Sensitivity Day Mode:	0.1 lx (F1.6, 50 % IRE, ICR off)
Sensitivity Night Mode:	0.05 lx (F1.6, 50 % IRE, ICR on)
Exposure / Image Enhancements:	Auto or Manual
Focus Type:	Automatic with manual override
Focus Range:	<1.5m to Infinity
Useful Zoom Range (optical):	16° (0.5x) to 2° (2x)
Camera Module Zoom Range:	30x Optical zoom, 58.9° to 2,11°
Zoom type:	Stepped and Smooth
Zoom Range (digital):	4x, 6x, 8x, 12x
Maximum IFOV:	0.01917 mRAD / 52.1629

DISPLAY	
Display Modes:	UV+VIS, UV+LWIR, VIS only, LWIR only, UV only, UV Priority
UV Overlay Accuracy:	<1 milirad deviation
On Screen Display:	Gain, zoom, count, active functions

ACCESSORIES	
Gimbal Compatibility	Includes: Gremsy T3 and more

SYSTEM SPECIFICATIONS:

CoroCAM 8HD UAV Brochure Version: 2023/1
Specifications subject to change without notice

IO & OS	
OS Features:	Icon based menu system
	10x User Profiles
	Boot to inspection capable in 6s, to record capable in 60s.
	Image Sort Numbering
	Video list and playback
Input:	Keypad, RS232, Ethernet, SBUS, CAN, PPM
Output:	HDMI, Composite Video
	Onboard speaker
Bi-Directional:	Micro USB, RS-232
Firmware:	Internal GPS, with external hotplug booster antenna
Light source:	LED Flashlight (Adjustable brightness , 10-100% usable range)
Software Update:	Via files downloaded from website to Mirco SD card
OS Features:	Icon based menu system

MEDIA & DATA STORAGE	
Storage Medium:	Micro SD card (32 GB supplied with camera)
Storage Capacity:	1000+ images or >1 hr video/GB
Storage Format Video:	AVI, (H.264 compression)
Storage Format Still:	JPG
Storage Format Radiometric Still:	UCF
Media Download:	Via Card Reader or USB

PROTECTION	
Storage / Transport Case:	Pelican style plastic hard case
Environmental Protection:	IP43
Safety Standard:	CE, IEC61010-1
Warranty:	12 months

PHYSICAL SPECIFICATION	
Useage:	Mounted
Weight:	1.6 Kg including battery
Dimensions:	188 mm L x 156 mm W x 129 mm H
Window aperture:	Ø = 62 mm
Operating Temp:	-15 °C to 55 °C
Storage Temp:	-20 °C to 60 °C
Humidity:	Up to 90 %, non condensating
Mounting Point	Standard 1/4" X20 thread tripod mount

POWER	
Battery:	Sony Li-ion, Type L compatible
Battery Location:	Internal, quickly replaceable
Operating Time:	4hrs maximum
Continuous Operation:	No overheating
Charging:	In camera or in external charger
External Power Supply:	9-16V 12VA - Car or mains adapter Mains Adaptor: 110-240 V ac 50 - 60 Hz / 12 V dc 3A Protection: Reverse polarity, over current, under voltage



Website: www.uvirco.com
Address: UVIRCO Technologies (Pty) Ltd,
33 De Havilland Crescent, Perseus Technopark, Pretoria 0020, South Africa
Tel: +27 (0)12 349 3760 | Fax: +27 (0)86 435 5204 | Email: info@uvirco.com





With Optional Thermal
Module

CoroCAM® UVS1

Specialist UAV Corona Camera

The CoroCAM UVS1 is designed for UAV combination of the successful CoroCAM Solar Blind corona sensor and a HD visible camera in a lightweight package able to fit into smaller gimbals. The resulting system gives excellent UV sensitivity, a wide FOV for close up inspection and good resolving power.

Setup via bluetooth, with video and still recordings onto an onboard μ SD card, downlink the HDMI or composite output and input remote control commands via CANBUS / PWM / RS232 / Ethernet.

FEATURES:



DIMENSIONS:

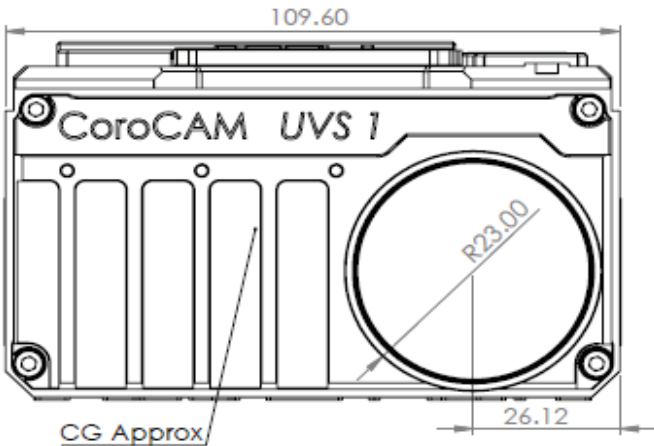

Front view

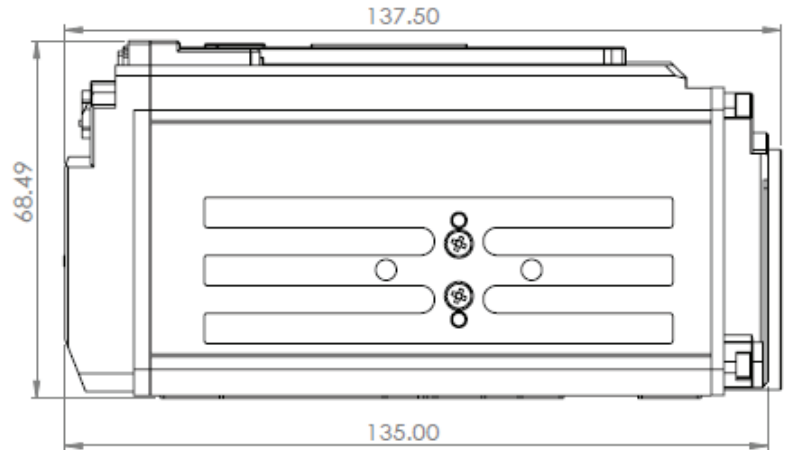

Side view

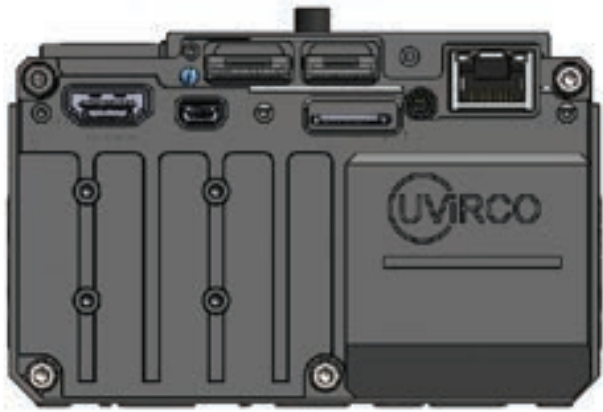

Back view

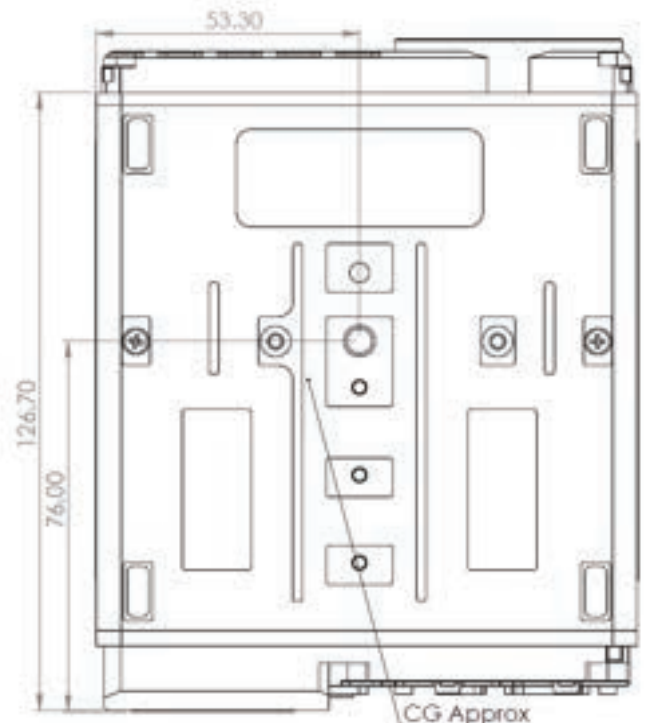

Bottom view

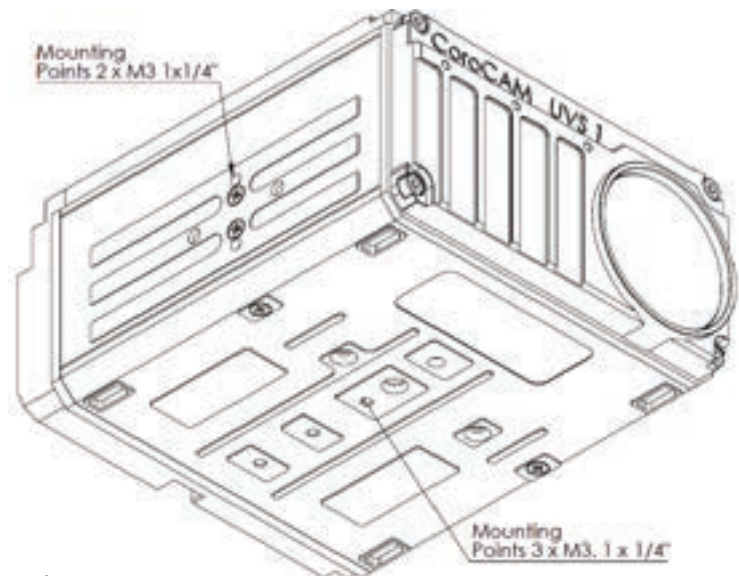

ALL DIMENSIONS IN mm Tol +0.1 -0.1mm

SYSTEM SPECIFICATIONS:

CoroCAM UVS1 Brochure Version: 2023/1
Specifications subject to change without notice

ULTRAVIOLET CHANNEL	
Typical Sensitivity:	SB (240 - 280 nm) 5×10^{-18} Watt/cm ² , 3.6pC @ 20m
Field of view:	19° Horizontal x 14° Vertical ~ 24° Diagonal Zoom Range (optical): 1x Zoom Range (digital): 16° to 6°
Focus type:	Linked to Visible with manual override
Focus Range:	3m to Infinity
Detector Life Span:	No degradation
Corona Measure Method:	Intensity based count, Calibrated for irradiance value of selected area
Threshold Mask:	Useful range 20-100%
UV Transparency:	0-100%
UV False Color Selection:	4 presets with 100 user selectable hues
UV Integration:	Adjustable period, Summation or Noise Reduction

VISIBLE CHANNEL	
Resolution:	1920 x 1080 pixels
Sensitivity Day Mode:	0.05 Lux F 1.6
Sensitivity Night Mode:	0.03 Lux F 1.6
Exposure / Image Enhancements:	Auto or Manual / Wide Dynamic Range
Focus Type:	Automatic with manual override
Focus Range:	3m to Infinity
Useful Zoom Range (optical):	16° (0.5x) to 4° (3x)
Camera Module Zoom Range:	10x, 53° to 4.9°
Zoom type:	Stepped
Zoom Range (digital):	4x, 6x, 8x, 12x
Maximum IFOV:	0.0445 mRAD

IO & OS	
OS Features:	Icon based menu system, 10x User Profile, Boot to inspection capable in 6s, to record capable in 60s, Image Sort Numbering, Video list and playback
Input:	SBUS, (CAN or RS232 option), Ethernet; ON/OFF Switch (Always ON Selection via Jumper), Bluetooth Pairing, Record Start/Stop
Output:	HDMI via port or Ethernet / Wi-Fi (optional) & Composite Video (10 pin accessory port) Optional Wi-Fi - deactivates ethernet & adds 100g
Firmware:	Internal GPS, with external antenna via MCX connector
Software Update:	Via files downloaded from website to Mirco SD card

MEDIA & DATA STORAGE	
Storage Medium:	Micro SD card (64 GB supplied with camera)
Storage Capacity:	1000+ images or >1 hr video/GB
Storage Format Video:	AVI, 720p (H.264 compression)
Storage Format Still:	JPG
Media Download:	Via Card Reader or USB

SYSTEM SPECIFICATIONS:

CoroCAM UVS1 Brochure Version: 2023/1
Specifications subject to change without notice

DISPLAY

Display Modes:	UV+VIS, UV+LWIR, VIS only, LWIR only, UV only, UV Priority
UV Overlay Accuracy:	<1 milirad deviation
On Screen Display:	Gain, zoom, count, active functions

POWER

Battery:	N/A
Power Consumption:	12 Watt
Operating Time:	Depending on Power supply (External or UAV battery) Typical 3hrs on 40W battery
Continuous Operation:	No overheating
Charging:	N/A
External Power Supply:	9-60 V 12VA - Car or mains adapter Mains Adaptor: 110-240 V ac 50 - 60 Hz / 12 V dc 3A Protection: Reverse polarity, over current, under voltage

PHYSICAL SPECIFICATION

Useage:	Mounted horizontal (standard) or mounted vertical (optional)
Weight:	740 g without the brackets 800 g with Boson Module 1.25 Kg with the Pixy - C gimbal, brackets and thermal
Dimensions:	110 mm L x 143 mm W x 67 mm H
Window aperture:	Ø = 62 mm
Operating Temp:	-15 °C to 55 °C
Storage Temp:	-20 °C to 60 °C
Humidity:	Up to 90 %, non condensating
Mounting Point	Standard 1/4" X20 thread tripod mount at bottom, M3 mounts bottom and right side
Center of Gravity	70 - 64 mm from rear (Depending on Options)

PROTECTION

Storage / Transport Case:	Pelican style plastic hard case
Environmental Protection:	IP44 (Optional IP 65)
Safety Standard:	CE, IEC1010-1
Warranty:	12 months

WITH OPTIONAL THERMAL MODULES

THERMAL	FLIR TAU 2	FLIR BOSON
Spectral Band:	7.5 - 13.5 µm	8µm - 14µm
Sensitivity:	<50 mK	<50 mK
Resolution:	640 × 512	640 × 512
Field of View:	32° x 26°	24° x 19.2°
Level & Span:	Auto or Manual	Auto or Manual



Website: www.uvirco.com
Address: UVIRCO Technologies (Pty) Ltd,
33 De Havilland Crescent, Persequor Technopark, Pretoria 0020, South Africa
Tel: +27 (0)12 349 3760 | Fax: +27 (0)86 435 5204 | Email: info@uvirco.com





Address: UViRCO Technologies (Pty) Ltd,
33 De Havilland Crescent, Perseus Technopark, Pretoria 0020, South Africa
Tel: +27 (0)12 349 3760 | Fax: +27 86 435 5204 | Email: info@uvirco.com

Distributed by

